

IFP BMG HIGH TORQUE LOW SPEED MOTORS



High Performance in an economical package

International BMG motors provide high output torque from an efficient compact design. Motors are available with displacements from 3.2 - 23.5 c.i.r (51.7 - 386.2 c.c.r). BMG motors provide smooth low speed performance while maintaining high output torque. Motors can be connected together in series, or parallel and their shaft seal design allow the motor to withstand high back pressures without an external case drain. When operated within their rated conditions these motors will provide a long trouble free service life.



Features:

- * High volumetric Efficiency
- * High Starting Torque
- * Series - Parallel Installation
- * Compact design

Model code

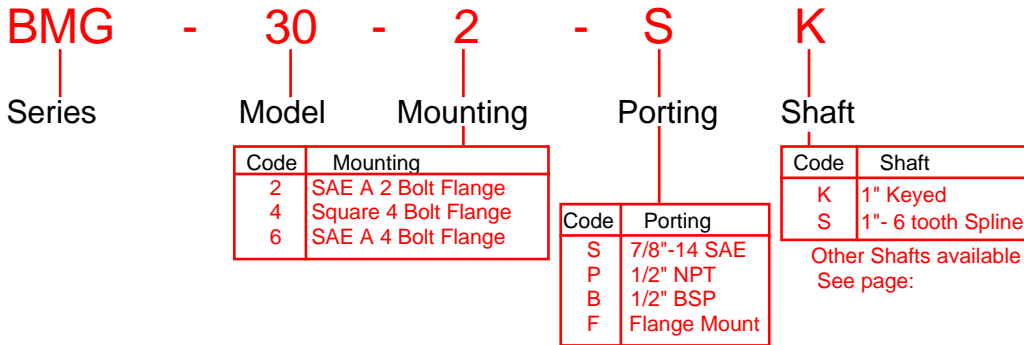

Model	BMG 30	BMG 49	BMG 61	BMG 76	BMG 98	BMG 122	BMG 152	BMG 192	BMG 244	
Displacement in ³ /rev (cm ³ /rev)	3.2 (51.7)	4.7 (77.7)	5.9 (96.2)	7.2 (117.9)	9.5 (155.5)	11.6 (189.9)	14.1 (231)	19.0 (311.7)	23.5 (386.2)	
Speed RPM	Continuous	879	740	589	475	370	296	237	189	149
	Intermittent	975	827	673	594	463	370	297	236	185
Torque in-lb (Nm)	Continuous	716 {81}	1141 {129}	1424 {161}	1787 {202}	2168 {245}	2531 {286}	3186 {360}	3593 {406}	3850 {435}
	Intermittent	929 {108}	1513 {171}	1885 {213}	2371 {268}	3026 {342}	3451 {390}	4035 {456}	4469 {505}	4717 {533}
Power H.P. (kW)	Continuous	9.3 {7}	12.2 {9.1}	12.1 {9}	12.2 {9.1}	11.6 {8.7}	10.9 {8.1}	11.0 {8.2}	9.7 {7.2}	8.2 {6.1}
	Intermittent	11.9 {8.9}	15.8 {11.8}	16.0 {11.9}	15.8 {11.8}	16.0 {11.9}	14.6 {10.9}	13.5 {10.1}	11.5 {8.6}	9.7 {7.2}
Pressure PSI (Mpa)	Continuous	1810 {12.5}	1810 {12.5}	1810 {12.5}	1810 {12.5}	1810 {12.5}	1595 {11}	1595 {11}	1595 {11}	1450 {10}
	Intermittent	2393 {16.5}	2393 {16.5}	2393 {16.5}	2393 {16.5}	2393 {16.5}	2393 {16.5}	2030 {14}	1810 {12.5}	1520 {10.5}
Flow GPM (LPM)	Continuous	12 {45}	16 {60}	16 {60}	16 {60}	16 {60}	16 {60}	16 {60}	16 {60}	16 {60}
	Intermittent	13.2 {50}	20 {75}	20 {75}	20 {75}	20 {75}	20 {75}	20 {75}	20 {75}	20 {75}
Weight Lbs (kg)	12.3 {5.6}	12.6 {5.7}	13.0 {5.9}	13.2 {6}	13.7 {6.2}	14.1 {6.4}	14.6 {6.6}	15.2 {6.9}	16.3 {7.4}	

Continuous operation: Motor may be run continuously at these ratings.

Intermittent operation: Motor may be run 10% of every minute at these ratings

Intermittent speed & intermittent pressure must not occur simultaneously

Recommended fluids: Premium quality, anti-wear type hydraulic oil

Recommended Temperature: 180 F { 82 C }

Recommended filtration: per ISO Cleanliness code, level 18/13

IFP BMG HIGH / TORQUE LOW / SPEED MOTORS

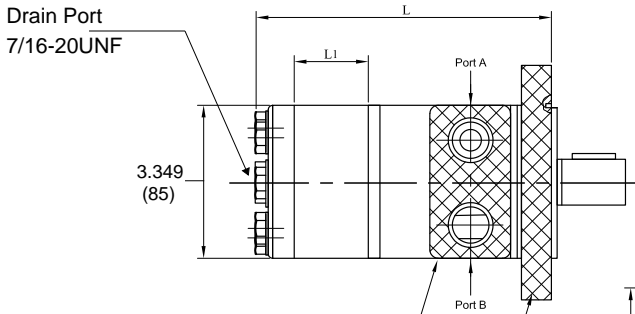

Porting: Threaded

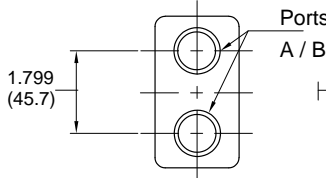

Code: S = A / B ports 7/8-14 UNF

Code: P = A / B ports 1/2 NPTF

Code: B = A / B ports 1/2 BSP

Porting: Flanged

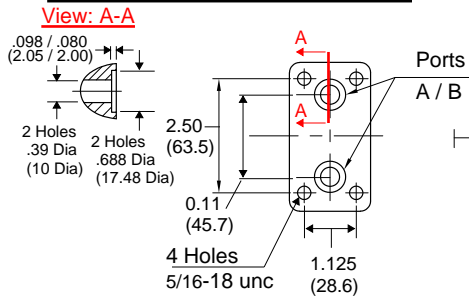

Mounting

Code: 2
SAE-A 2 Bolt

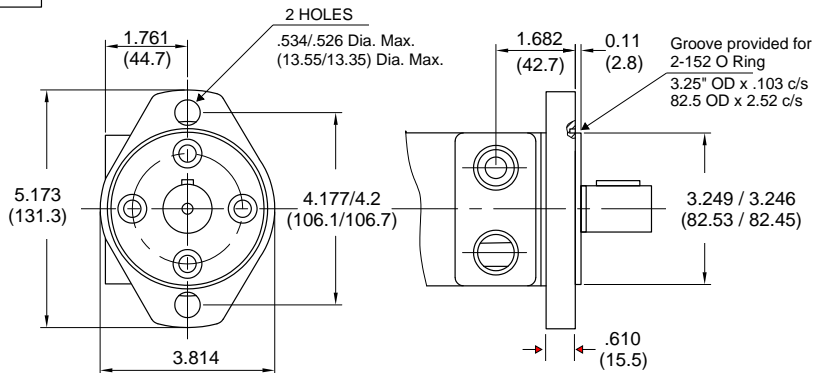

Code: 6
Magneto Mount / 4 Bolt

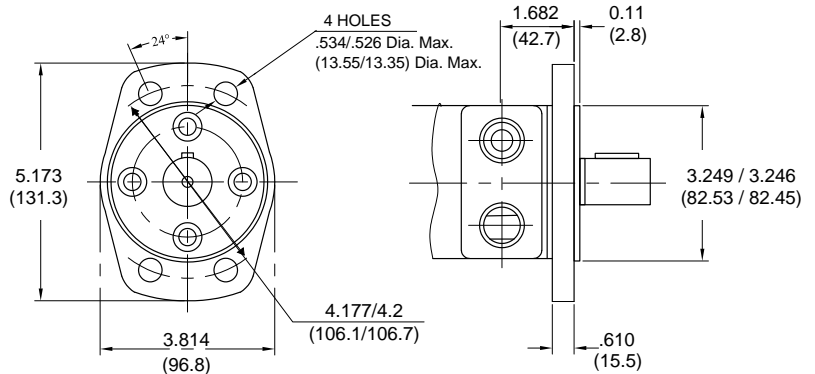

Code: 4
Square Mount 4 Bolt

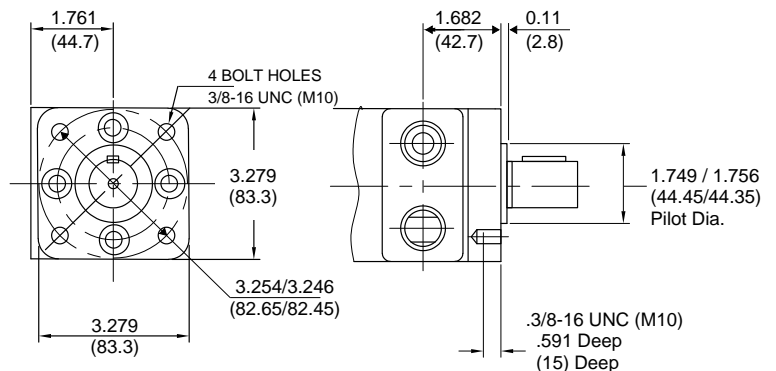

Dimensions: Inches (millimeters)

Code	Dimension L	Dimension: L1
BMG30	5.55 (141)	.27 (7)
BMG49	5.68 (144.5)	.41 (10.5)
BMG61	5.78 (147)	.51 (13)
BMG76	5.90 (150)	.62 (16)
BMG98	6.10 (155)	.82 (21)
BMG122	6.29 (160)	1.02 (26)
BMG152	6.53 (166)	1.25 (32)
BMG192	6.92 (176)	1.65 (42)
BMG244	7.32 (186)	2.04 (52)

IFP BMG MOTOR DRIVE SHAFT SPECIFICATIONS



Code: K ** Standard shaft **
1 Inch Dia. Straight with Woodruff Key

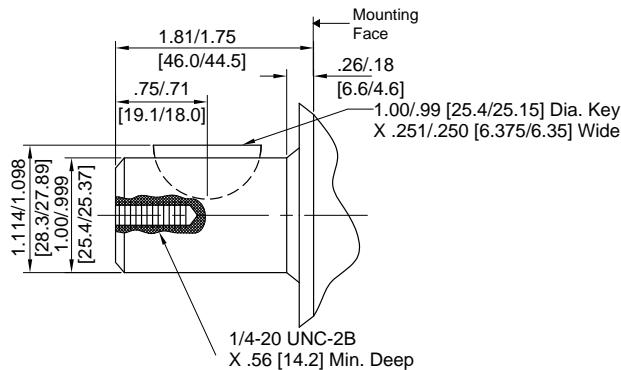

Code: D ** Special Order **
7/8 Inch Dia. Straight Shaft with Key

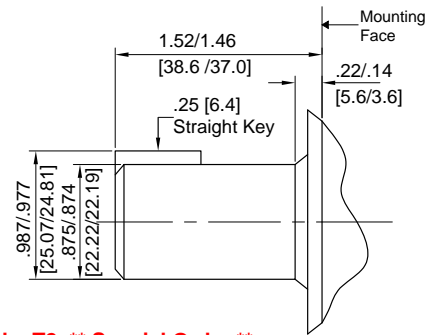

Code: T2 ** Special Order **
1 Inch Dia. Tapered Shaft With Woodruff Key & Nut

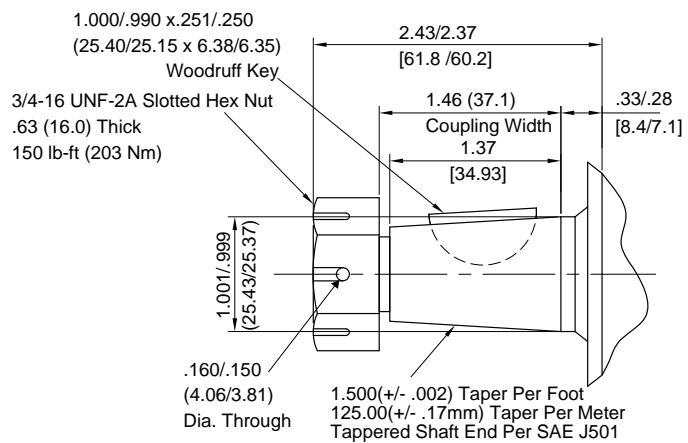

Code: A ** Special Order **
1 Inch Dia. Straight with Woodruff Key

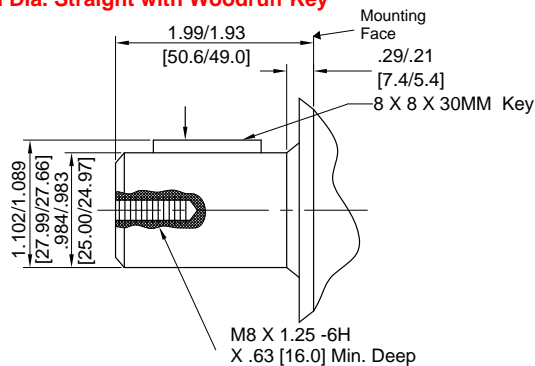

Code: H1 ** Special Order **
1 Inch Dia. Straight Shaft with .315 Crosshole

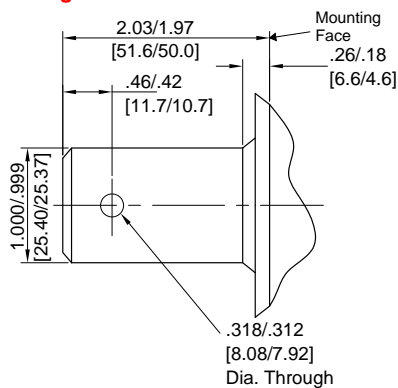

Code: H ** Special Order **
1 Inch Dia. Straight Shaft with .406 Crosshole

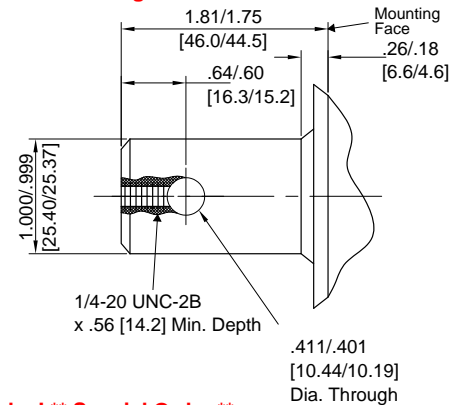

Code: S ** Special Order **
SAE 6 B 1" Dia. Splined Shaft

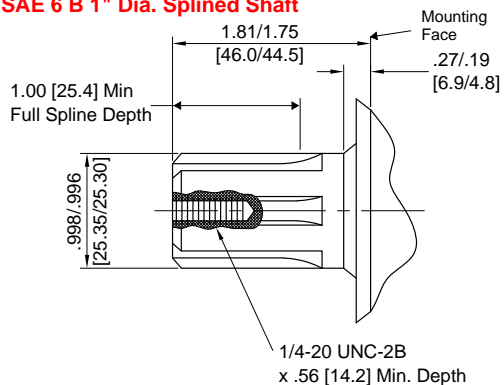

Code: I ** Special Order **
7/8" Dia. 13 tooth SAE-B Splined Shaft

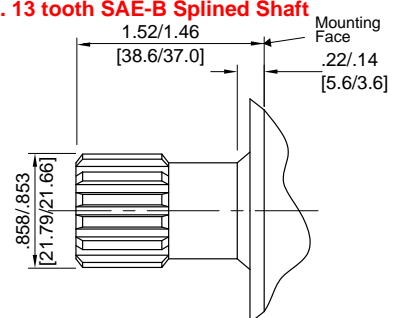

IFF BMG MOTOR PERFORMANCE DATA



BMG30: 3.2 in3/rev {51.7 cm3/rev}

BMG49: 4.7 in3/rev {77.7 cm3/rev}

		Pressure- PSI {Mpa}							max. Cont.	max. Int.
		435 {3}	870 {6}	1015 {7}	1160 {8}	1450 {10}	1595 {11}	1812 {12.5}	2393 {16.5}	
Flow GPM {LPM}	2 {8}	150 {17}	336 {38}	389 {44}	443 {50}	558 {63}	620 {70}	700 {79}	920 {104}	
	4 {15}	168 {19}	336 {38}	389 {44}	443 {50}	556 {64}	628 {71}	708 {80}	929 {105}	
	5.3 {20}	150 {17}	336 {38}	389 {44}	451 {51}	566 {64}	628 {71}	708 {80}	947 {107}	
	8 {30}	141 {16}	327 {37}	389 {44}	443 {50}	566 {64}	628 {71}	716 {81}	955 {108}	
	9.3 {35}	132 {15}	318 {36}	380 {43}	443 {50}	557 {63}	628 {71}	708 {80}	947 {107}	
	12 {45}	123 {14}	300 {34}	371 {42}	433 {49}	557 {63}	620 {70}	708 {80}	947 {107}	
Max. Cont.	13.2 {50}	115 {13}	292 {33}	363 {41}	424 {48}	548 {63}	601 {68}	699 {79}		

		Pressure- PSI {Mpa}							max. Cont.	max. Int.
		435 {3}	870 {6}	1015 {7}	1160 {8}	1450 {10}	1595 {11}	1812 {12.5}	2393 {16.5}	
Flow GPM {LPM}	2 {8}	256 {29}	531 {60}	619 {70}	708 {80}	894 {101}	982 {111}	1132 {128}	1486 {168}	
	4 {15}	256 {29}	539 {61}	628 {71}	717 {81}	894 {101}	1008 {114}	1141 {129}	1504 {170}	
	5.3 {20}	247 {28}	531 {60}	628 {71}	717 {81}	894 {101}	991 {112}	1141 {129}	1504 {170}	
	8 {30}	221 {25}	513 {58}	610 {69}	699 {79}	885 {100}	982 {111}	1132 {128}	1513 {171}	
	9.3 {35}	212 {24}	504 {57}	601 {68}	690 {78}	876 {99}	973 {110}	1115 {126}	1513 {171}	
	12 {45}	194 {22}	478 {54}	584 {66}	681 {77}	858 {97}	964 {109}	1097 {124}	1495 {169}	
Max. Cont.	13.2 {50}	177 {20}	469 {53}	566 {64}	663 {75}	849 {96}	947 {107}	1088 {123}	1486 {168}	
Max. Int.	16 {60}	168 {19}	460 {52}	558 {63}	655 {74}	840 {95}	947 {107}	1088 {123}	1486 {168}	
	20 {75}	141 {16}	415 {47}	522 {59}	637 {72}	805 {91}	929 {105}	1070 {121}		
		827 {82}	820 {82}	817 {81}	813 {81}	808 {80}	804 {80}	796 {79}		

Torque - lb-in {Nm}
Speed - RPM

BMG61: 5.9 in3/rev {96.2 cm3/rev}

BMG76: 7.2 in3/rev {117.9 cm3/rev}

		Pressure- PSI {Mpa}							max. Cont.	max. Int.
		435 {3}	870 {6}	1015 {7}	1160 {8}	1450 {10}	1595 {11}	1812 {12.5}	2393 {16.5}	
Flow GPM {LPM}	2 {8}	318 {36}	663 {75}	778 {88}	893 {101}	1115 {126}	1247 {141}	1416 {160}	1858 {210}	
	4 {15}	309 {35}	663 {75}	787 {89}	893 {101}	1132 {128}	1247 {141}	1416 {160}	1885 {213}	
	5.3 {20}	292 {33}	655 {74}	778 {88}	893 {101}	1115 {126}	1239 {140}	1424 {161}	1876 {212}	
	8 {30}	274 {31}	637 {72}	752 {85}	867 {98}	1088 {123}	1212 {137}	1389 {157}	1885 {213}	
	9.3 {35}	256 {29}	610 {69}	734 {83}	849 {96}	1070 {121}	1194 {135}	1371 {155}	1876 {212}	
	12 {45}	247 {28}	584 {66}	716 {81}	832 {94}	1053 {119}	1177 {133}	1354 {153}	1840 {208}	
Max. Cont.	13.2 {50}	212 {24}	575 {65}	690 {78}	823 {93}	1035 {117}	1168 {132}	1345 {152}	1832 {207}	
Max. Int.	16 {60}	203 {23}	557 {63}	681 {77}	814 {92}	1026 {116}	1159 {131}	1336 {151}	1832 {207}	
	20 {75}	177 {20}	504 {57}	655 {74}	778 {88}	1000 {113}	1141 {129}	1327 {150}		

		Pressure- PSI {Mpa}							max. Cont.	max. Int.
		435 {3}	870 {6}	1015 {7}	1160 {8}	1450 {10}	1595 {11}	1812 {12.5}	2393 {16.5}	
Flow GPM {LPM}	2 {8}	398 {45}	831 {94}	982 {111}	1124 {127}	1398 {158}	1557 {176}	1778 {201}	2327 {263}	
	4 {15}	389 {44}	831 {94}	982 {111}	1124 {127}	1416 {160}	1566 {177}	1787 {202}	2363 {267}	
	5.3 {20}	371 {42}	823 {93}	973 {110}	1124 {127}	1407 {159}	1557 {176}	1787 {202}	2371 {268}	
	8 {30}	354 {40}	805 {91}	955 {108}	1097 {124}	1380 {156}	1548 {174}	1752 {198}	2371 {268}	
	9.3 {35}	336 {38}	787 {89}	938 {106}	1074 {122}	1363 {154}	1522 {172}	1734 {196}	2363 {267}	
	12 {45}	327 {37}	752 {85}	911 {103}	1062 {120}	1336 {151}	1504 {170}	1717 {194}	2327 {263}	
Max. Cont.	13.2 {50}	292 {33}	743 {84}	885 {100}	1044 {118}	1318 {149}	1478 {167}	1619 {192}	2301 {260}	
Max. Int.	16 {60}	283 {32}	717 {81}	876 {99}	1026 {116}	1301 {147}	1469 {166}	1690 {191}	2292 {259}	
	20 {75}	230 {26}	663 {75}	823 {93}	973 {110}	1256 {142}	1407 {159}	1637 {185}		

Torque - lb-in {Nm}
Speed - RPM

Continuous -
Intermittent -

IFP BMG MOTOR PERFORMANCE DATA



BMG98: 9.5 in3/rev {155.5 cm3/rev}

BMG122: 11.6 in3/rev {189.9 cm3/rev}

		Pressure- PSI {Mpa}						max. Cont.	max. Int.
		435 {3}	870 {6}	1015 {7}	1160 {8}	1450 {10}	1595 {11}	2030 {14}	2393 {16.5}
Flow GPM {LPM}	2 {8}	504 {57}	1070 {121}	1256 {142}	1433 {162}	1787 {202}	1991 {225}	2150 {243}	2956 {334}
	4 {15}	495 {56}	1070 {121}	1256 {142}	1433 {162}	1805 {204}	2009 {227}	2168 {245}	3018 {341}
	5.3 {20}	486 {55}	1062 {120}	1239 {140}	1433 {162}	1796 {203}	2000 {226}	2159 {244}	3026 {342}
	8 {30}	477 {54}	1035 {117}	1230 {139}	1416 {160}	1778 {201}	1982 {224}	2141 {242}	3009 {340}
	9.3 {35}	460 {52}	1017 {115}	1212 {137}	1407 {159}	1761 {199}	1947 {220}	2141 {242}	2982 {337}
	12 {45}	442 {50}	991 {112}	1185 {134}	1380 {156}	1734 {196}	1947 {220}	2106 {238}	2964 {335}
	13.2 {50}	398 {45}	973 {110}	1168 {132}	1354 {153}	1734 {196}	1911 {216}	2062 {233}	2920 {330}
	Max. Cont. 16 {60}	389 {44}	938 {106}	1150 {130}	1336 {151}	1734 {196}	1894 {214}	2044 {231}	2903 {328}
Max. Int. 20 {75}	283 {32}	849 {96}	1053 {119}	1256 {142}	1610 {182}	1814 {205}	1964 {222}		

		Pressure- PSI {Mpa}						max. Cont.	max. Int.
		435 {3}	870 {6}	1015 {7}	1160 {8}	1450 {10}	1595 {11}	2175 {15}	
Flow GPM {LPM}	2 {8}	646 {73}	1354 {153}	1584 {179}	1805 {204}	2265 {256}	2504 {283}	3407 {385}	
	4 {15}	646 {73}	1345 {152}	1593 {180}	1814 {205}	2292 {259}	2531 {286}	3451 {390}	
	5.3 {20}	628 {71}	1336 {151}	1575 {178}	1805 {204}	2265 {256}	2522 {285}	3451 {390}	
	8 {30}	601 {68}	1318 {149}	1548 {175}	1787 {202}	2248 {254}	2504 {283}	3434 {388}	
	9.3 {35}	575 {65}	1292 {146}	1531 {173}	1770 {200}	2230 {252}	2487 {281}	3416 {386}	
	12 {45}	557 {63}	1256 {142}	1504 {170}	1734 {196}	2186 {247}	2451 {277}	3380 {382}	
	13.2 {50}	513 {58}	1221 {138}	1469 {166}	1708 {193}	2159 {244}	2407 {272}	3345 {378}	
	Max. Cont. 16 {60}	495 {56}	1203 {136}	1442 {163}	1690 {191}	2133 {241}	2380 {269}	3319 {375}	
Max. Int. 20 {75}	371 {42}	1070 {121}	1327 {150}	1566 {177}	2000 {226}				

Torque: lb-in {Nm}
Speed: RPM

BMG152: 14.1 in3/rev {231 cm3/rev}

		Pressure- PSI {Mpa}						max. Cont.	max. Int.
		435 {3}	870 {6}	1015 {7}	1160 {8}	1450 {10}	1595 {11}	2030 {14}	
Flow GPM {LPM}	2 {8}	823 {93}	1725 {195}	2000 {226}	2292 {259}	2876 {325}	3159 {357}		
	4 {15}	814 {92}	1699 {192}	2000 {226}	2301 {260}	2876 {325}	3186 {360}	4035 {456}	
	5.3 {20}	796 {90}	1690 {191}	1991 {225}	2283 {258}	2849 {322}	3150 {356}	4027 {455}	
	8 {30}	761 {86}	1663 {188}	1956 {221}	2256 {255}	2823 {319}	3133 {354}	4000 {452}	
	9.3 {35}	725 {82}	1628 {184}	1920 {217}	2221 {251}	2805 {317}	3097 {350}	3965 {448}	
	12 {45}	699 {79}	1584 {179}	1894 {214}	2177 {246}	2761 {312}	3053 {345}	3912 {442}	
	13.2 {50}	654 {74}	1540 {174}	1849 {209}	2150 {243}	2708 {306}	3000 {339}	3876 {438}	
	Max. Cont. 16 {60}	628 {71}	1513 {171}	1823 {206}	2115 {239}	2681 {303}	2973 {336}	3832 {433}	
Max. Int. 20 {75}	469 {53}	1354 {153}	1672 {189}	1956 {221}	2478 {280}	2761 {312}			

Continuous -
Intermittent -

IFF BMG MOTOR PERFORMANCE DATA



BMG192: 19 in³/rev {311.7 cm³/rev}

		Pressure- PSI {Mpa}				max. Cont.	max. Int.
		435 {3}	870 {6}	1015 {7}	1160 {8}	1450 {10}	1812 {12.5}
Flow GPM {LPM}	2 {8}	1026 {116}	2150 {243}	2495 {282}	2770 {313}	3434 {388}	
		25	24	22	16	13	
	4 {15}	1017 {115}	2150 {243}	2513 {284}	2867 {324}	3593 {406}	4451 {503}
		47	46	45	43	41	20
	5.3 {20}	1008 {114}	2141 {242}	2495 {282}	2858 {323}	3584 {405}	4469 {505}
		63	62	61	58	56	44
	8 {30}	964 {109}	2097 {237}	2451 {277}	2823 {319}	3549 {401}	4434 {501}
		94	93	92	90	88	77
	9.3 {35}	929 {105}	2053 {232}	2416 {273}	2779 {314}	3513 {397}	4398 {497}
		110	109	108	106	103	93
12 {45}	876 {99}	2000 {226}	2371 {268}	2734 {309}	3460 {391}	4345 {491}	
	141	141	139	137	135	124	
13.2 {50}	814 {92}	1929 {218}	2318 {262}	2690 {304}	3398 {384}	4301 {486}	
	157	157	155	154	151	141	
Max. Cont. 16 {60}	787 {89}	1902 {215}	2283 {258}	2646 {299}	3354 {379}	4239 {479}	
	189	188	187	185	182	171	
Max. Int. 20 {75}	610 {69}	1717 {194}	2097 {237}	2460 {278}	3142 {355}		
	236	235	234	232	229		

BMG244: 23.5 in³/rev {386.2 cm³/rev}

		Pressure- PSI {Mpa}				max. Cont.	max. Int.
		435 {3}	870 {6}	1015 {7}	1160 {8}	1232 {8.5}	1812 {12.5}
Flow GPM {LPM}	2 {8}	1301 {147}	2690 {304}	3133 {354}			
		20	19	16			
	4 {15}	1301 {147}	2726 {308}	3177 {359}	3611 {408}	3850 {435}	4708 {532}
		37	36	35	33	32	25
	5.3 {20}	1274 {144}	2699 {305}	3168 {358}	3602 {407}	3850 {435}	4717 {533}
		50	49	47	45	43	38
	8 {30}	1230 {139}	2664 {301}	3115 {352}	3557 {402}	3805 {430}	4690 {530}
		74	73	72	70	68	62
	9.3 {35}	1177 {133}	2602 {294}	3053 {345}	3504 {396}	3743 {423}	4646 {525}
		86	86	85	82	80	75
12 {45}	1106 {125}	2540 {287}	3000 {339}	3442 {389}	3681 {416}	4575 {517}	
	111	111	109	106	105	100	
13.2 {50}	1035 {117}	2460 {278}	2920 {330}	3380 {382}	3619 {409}	4505 {509}	
	124	124	122	120	119	113	
Max. Cont. 16 {60}	991 {112}	2425 {274}	2885 {326}	3336 {377}	3575 {404}	4469 {505}	
	149	149	147	145	144	137	
Max. Int. 20 {75}	778 {88}	2177 {246}	2637 {298}	3106 {351}	3327 {376}		
	185	185	185	182	181		

Torque: lb-in { Nm }
Speed: RPM

Continuous -
Intermittent -

IFP HIGH TORQUE GEROTER MOTORS

Parts Service Information



"BMG SERIES"

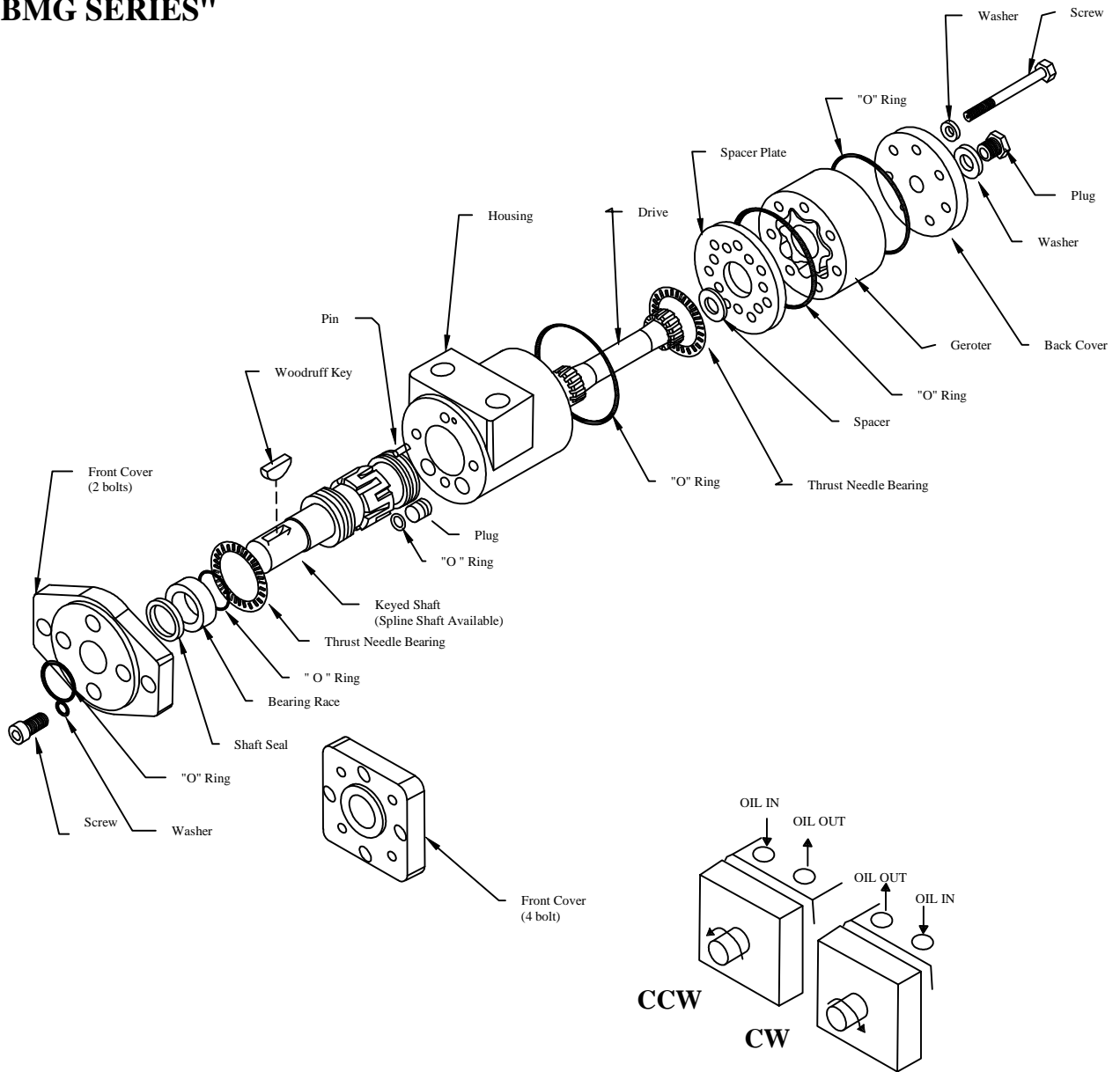

MOTOR ROTATION

FACTORY TIMING OF MOTOR WILL PRODUCE FOLLOWING ROTATIONS WHEN INLET AND OUTLET PORTS ARE ORIENTATED AS SHOW AS ABOVE DIAGRAMS

CROSS REFERENCE BMG GEROTOR SERIES



*INDICATES STANDARD STOCK UNITS
STANDARD 4 BOLT/KEYED SHAFT(SPLINE SHAFTS AVAILABLE)

IFP MODEL	DISPL in/rev	CHARLYNN "H" MODEL	DISPL in/rev	DANFOSS "OMP" MODEL	DISPL in/rev	PORTS SIZE
		101-1749 101-1753	2.2			1/2 NPTF SAE 7/8-14
BMG030-4PK *BMG030-4SK	3.0	101-1009 101-1001	2.8	151-2041 151-2121	3.0	1/2 NPTF SAE 7/8-14
BMG030-4PK *BMG030-4SK	3.0	101-1750 101-1754	3.6	151-2041 151-2121	3.0	1/2 NPTF SAE 7/8-14
BMG049-4PK *BMG049-4SK	4.9	101-1002 101-1010	4.5	151-2122 151-2042	4.7	1/2 NPTF SAE 7/8-14
BMG061-4PK *BMG061-4SK	6.1	101-1003 101-1011	5.9	151-2123 151-2043	5.9	1/2 NPTF SAE 7/8-14
BMG076-4PK *BMG076-4SK	7.6	101-1755 101-1751	7.3	151-2124 151-2044	7.6	1/2 NPTF SAE 7/8-14
		101-1752 101-1756	8.9			1/2 NPTF SAE 7/8-14
BMG098-4PK *BMG098-4SK	9.8	101-1004 101-1012	9.7	151-2125 151-2045	9.5	1/2 NPTF SAE 7/8-14
BMG122-4PK *BMG122-4SK	12.2	101-1005 101-1013	11.3	151-2026 151-2046	11.9	1/2 NPTF SAE 7/8-14
BMG152-4PK *BMG152-4SK	15.2	101-1006 101-1014	14.1	151-2127 151-2047	14.8	1/2 NPTF SAE 7/8-14
BMG192-4PK *BMG192-4SK	19.2	101-1007 101-1015	17.9	151-2128 151-2048	18.7	1/2 NPTF SAE 7/8-14
BMG244-4PK *BMG244-4SK	24.4	101-1008 101-1016	22.6	151-2129 151-2049	23.7	1/2 NPTF SAE 7/8-14

STANDARD 2 BOLT/KEYED SHAFT(SPLINE SHAFTS AVAILABLE)

IFP MODEL	DISPL in/rev	CHARLYNN "H" MODEL	DISPL in/rev	DANFOSS "OMP" MODEL	DISPL in/rev	PORTS SIZE
		101-1704 101-1700	2.2			1/2 NPTF SAE 7/8-14
BMG030-2PK *BMG030-2SK	3.0	101-1025 101-1033	2.8	151-2081 151-2001	3.0	1/2 NPTF SAE 7/8-14
BMG030-2PK *BMG030-2SK	3.0	101-1705 101-1701	3.6	151-2084 151-2001	3.0	1/2 NPTF SAE 7/8-14
BMG049-2PK *BMG049-2SK	4.9	101-1026 101-1036	4.5	151-2082 151-2002	4.7	1/2 NPTF SAE 7/8-14
BMG061-2PK *BMG061-2SK	6.1	101-1027 101-1035	5.9	151-2083 151-2003	5.9	1/2 NPTF SAE 7/8-14
BMG076-2PK *BMG076-2SK	7.6	101-1706 101-1702	7.3	151-2084 151-2004	7.6	1/2 NPTF SAE 7/8-14
		101-1707 101-1703	8.9			1/2 NPTF SAE 7/8-14
BMG098-2PK *BMG098-2SK	9.8	101-1028 101-1036	9.7	151-2085 151-2005	9.5	1/2 NPTF SAE 7/8-14
BMG122-2PK *BMG122-2SK	12.2	101-1029 101-1037	11.3	151-2086 151-2006	11.9	1/2 NPTF SAE 7/8-14
BMG152-2PK *BMG152-2SK	15.2	101-1030 101-1038	14.1	151-2087 151-2007	14.8	1/2 NPTF SAE 7/8-14
BMG192-2PK *BMG192-2SK	19.2	101-1031 101-1039	17.9	151-2088 151-2008	18.7	1/2 NPTF SAE 7/8-14
BMG244-2PK *BMG244-2SK	24.4	101-1032 101-1040	22.6	151-2089 151-2009	23.7	1/2 NPTF SAE 7/8-14

IFP BMG HIGH TORQUE LOW SPEED MOTORS



TIMING PROCEDURE

STANDARD ROTATION

Motor rotation will be as shown in Figure #1 when the following timing procedure is used

- Position tooth slot#1 on shaft assembly in line with tooth slot#3 highest point of geroter

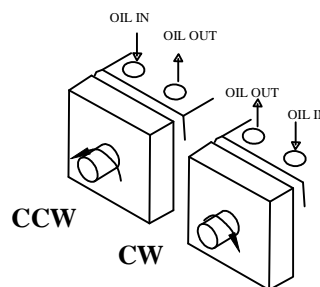
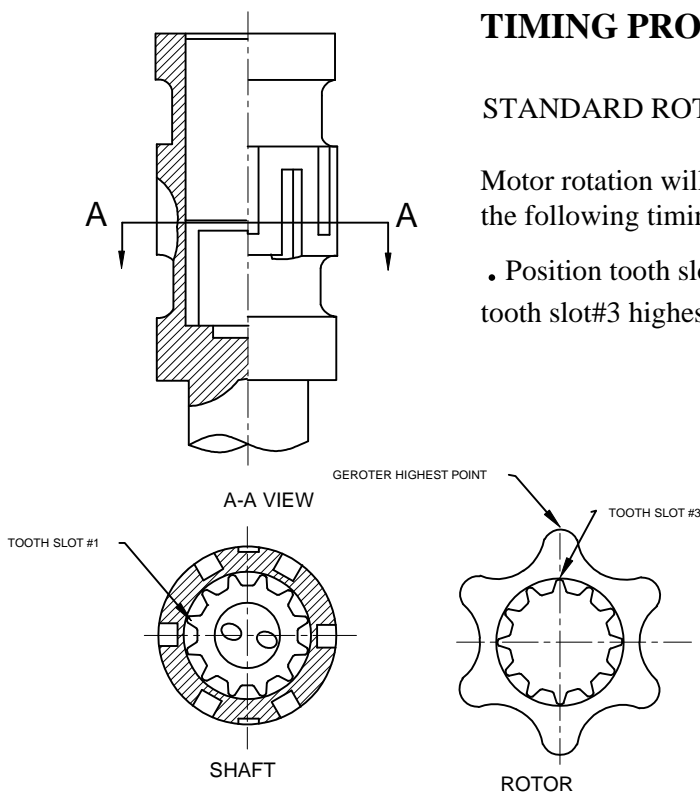

Figure #1

When timing is orientated as shown

TIMING PROCEDURE

REVERSE ROTATION

Motor rotation will be as shown in Figure #2 when the following timing procedure is used

- Position tooth slot#2 on shaft assembly in line with tooth slot#3 highest point of geroter

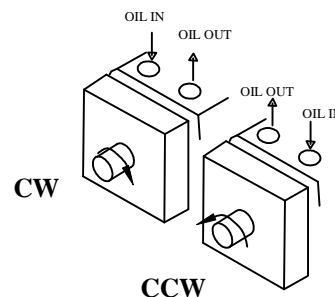
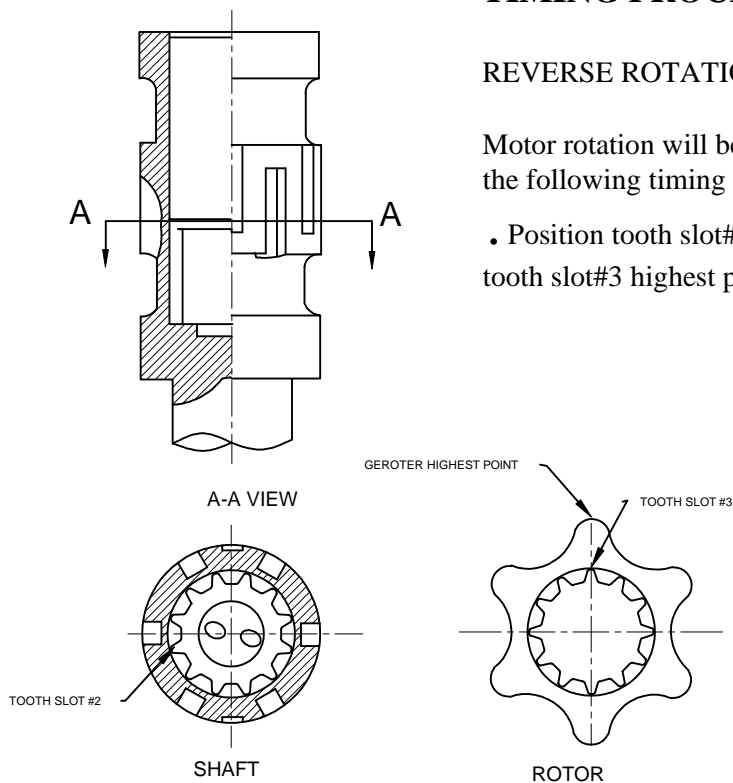

Figure #2

When timing is orientated as shown

IFP BML HIGH TORQUE LOW SPEED MOTORS



High Performance in an economical package

International BML motors provide high output torque from an efficient compact design. Motors are available with displacements from 3.1 - 22.6 c.i.r (51.3 - 370 c.c.r). BML motors provide smooth low speed performance while maintaining high output torque. Motors can be connected together in series, or parallel and their shaft seal design allow the motor to withstand high back pressures without an external case drain. When operated within their rated conditions these motors will provide a long trouble free service life.



Features:

- * High volumetric Efficiency
- * Geroler Assembly
- * Series - Parallel Installation
- * Compact design

Model code

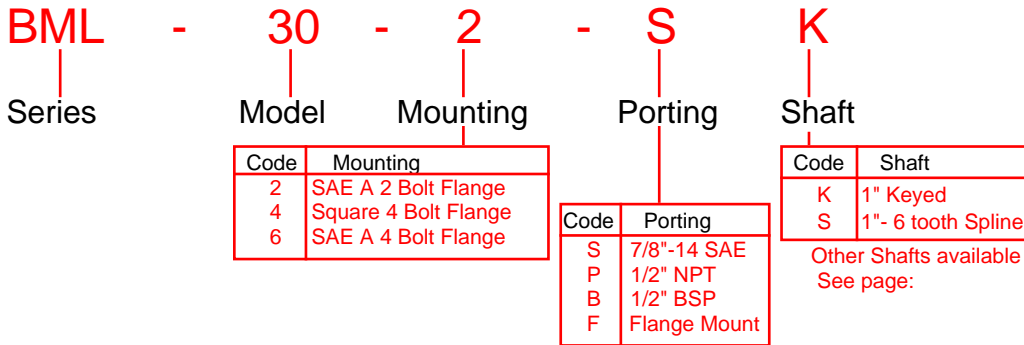

Model	BML 30	BML 49	BML 61	BML 76	BML 98	BML 122	BML 152	BML 192	BML 244	
Displacement in ³ /rev (cm ³ /rev)	3.1 (51.3)	4.9 (80.6)	6.1 (100.8)	7.6 (124.9)	9.6 (157.2)	12.2 (199.2)	15.4 (252)	19.2 (314.5)	22.6 (370)	
Speed RPM	Continuous	755	750	600	475	375	300	240	190	160
	Intermittent	970	940	750	600	470	375	300	240	200
Torque in-lb (Nm)	Continuous	885 {100}	1681 {190}	2124 {240}	2584 {292}	3212 {363}	3168 {358}	3115 {352}	3186 {360}	3717 {420}
	Intermittent	1115 {126}	1947 {220}	2478 {280}	3009 {340}	3805 {430}	3965 {448}	4159 {470}	4159 {470}	4850 {548}
Power H.P. (kW)	Continuous	103{7.7}	20.1 {15}	20.1 {15}	18.8 {14}	18.8 {14}	14.8 {11}	12.1 {9}	9.4 {7}	11.5 {8.6}
	Intermittent	13.0 {9.7}	22.8 {17}	22.8 {17}	21.4 {16}	21.4 {16}	18.8 {14}	16.1 {12}	12.1 {9}	16.1 {12}
Pressure PSI (Mpa)	Continuous	2030 {14}	2537 {17.5}	2537 {17.5}	2537 {17.5}	2392 {16.5}	1885 {13}	1595 {11}	1595 {11}	1450 {10}
	Intermittent	2537 {17.5}	2900 {20}	2900 {20}	2900 {20}	2900 {20}	2537 {17.5}	2030 {14}	1810 {12.5}	1667 {11.5}
Flow GPM (LPM)	Continuous	12 {45}	16 {60}	16 {60}	16 {60}	16 {60}	16 {60}	16 {60}	16 {60}	16 {60}
	Intermittent	13.2 {50}	20 {75}	20 {75}	20 {75}	20 {75}	20 {75}	20 {75}	20 {75}	20 {75}
Weight Lbs (kg)	14.8 {6.7}	15.2 {6.9}	15.3 {7.0}	15.8 {7.2}	16.5 {7.5}	17.6 {8.0}	18.7 {8.5}	19.8 {9.0}	20.5 {9.3}	

Continuous operation: Motor may be run continuously at these ratings.

Intermittent operation: Motor may be run 10% of every minute at these ratings

Intermittent speed & intermittent pressure must not occur simultaneously

Recommended fluids: Premium quality, anti-wear type hydraulic oil

Recommended Temperature: 180 F { 82 C }

Recommended filtration: per ISO Cleanliness code, level 18/13

IFP BML HIGH / TORQUE LOW / SPEED MOTORS

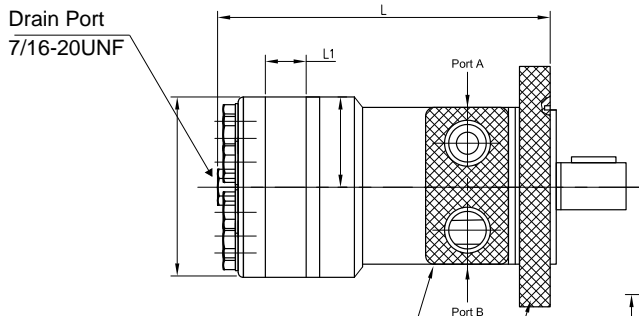

Mounting

Code: 2
SAE-A 2 Bolt

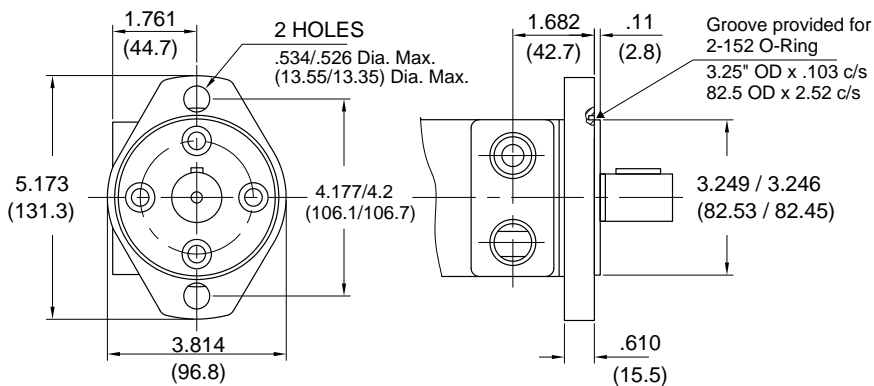

Porting: Threaded

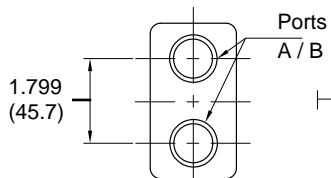

Code: S = A / B ports 7/8-14 UNF
Code: P = A / B ports 1/2" NPTF
Code: B = A / B ports 1/2" BSPT

Porting: Flanged

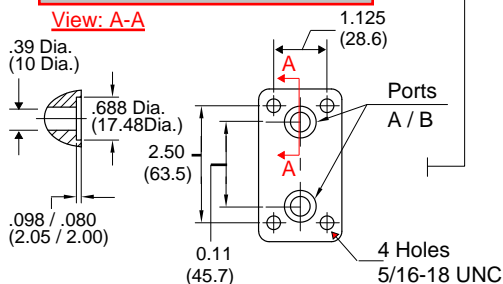

Code: 6
Magneto Mount 4 Bolt

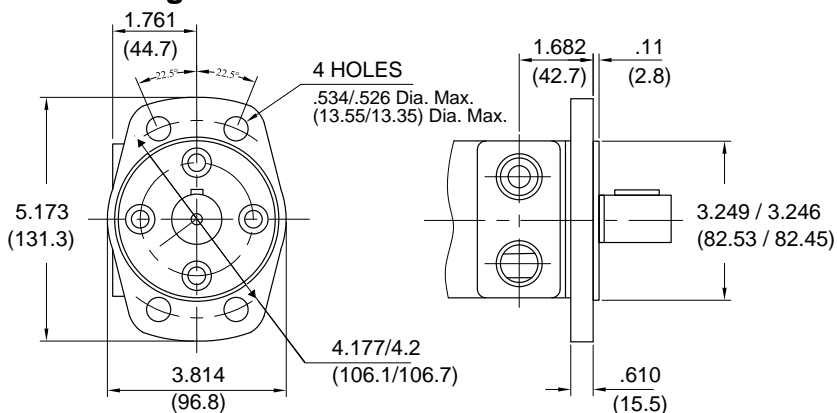

Code: 4
Square Mount 4 Bolt

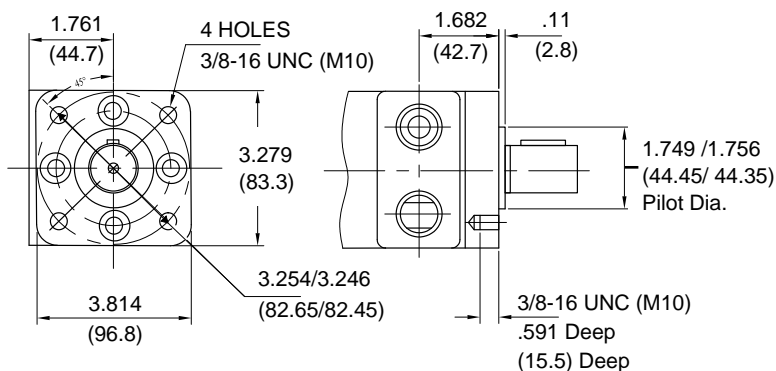

Code	Dimension: L	Dimension: L1
BML30	5.66 (144)	.39 (10)
BML49	5.90 (150)	.63 (16)
BML61	6.06 (154)	.79 (20)
BML76	6.26 (159)	.98 (25)
BML98	6.52 (155.5)	1.24 (31.5)
BML122	6.85 (174)	1.57 (40)
BML152	7.24 (184)	1.97 (50)
BML192	7.71 (196)	2.44 (62)
BML244	8.19 (208)	2.91 (74)

IFP BML MOTOR DRIVE SHAFT SPECIFICATIONS



Code: K ** Standard shaft **
1 Inch Dia. Straight with Woodruff Key

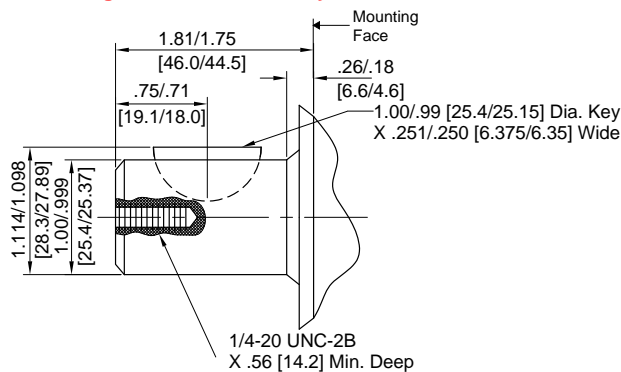

Code: D ** Special Order **
7/8 Inch Dia. Straight Shaft with Key

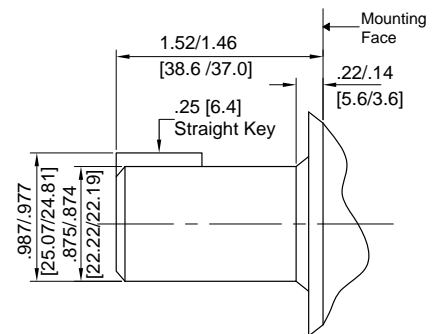

Code: T2 ** Special Order **
1 Inch Dia. Tapered Shaft With Woodruff Key & Nut

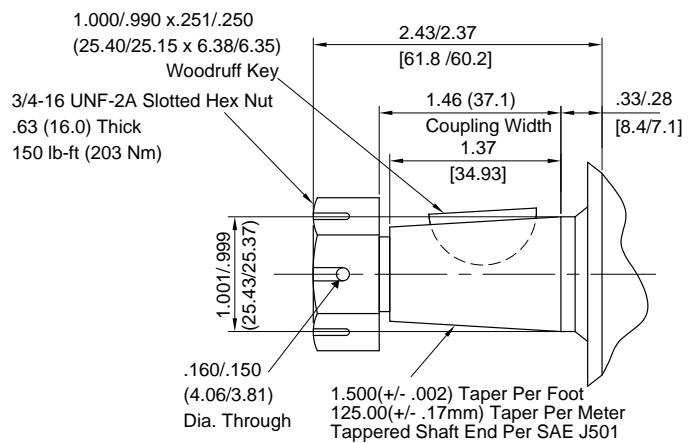

Code: A ** Special Order **
1 Inch Dia. Straight with Woodruff Key

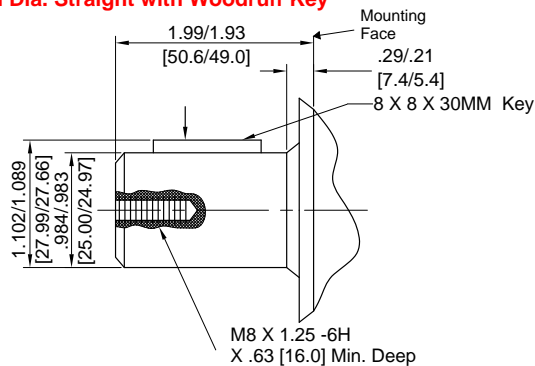

Code: H1 ** Special Order **
1 Inch Dia. Straight Shaft with .315 Crosshole

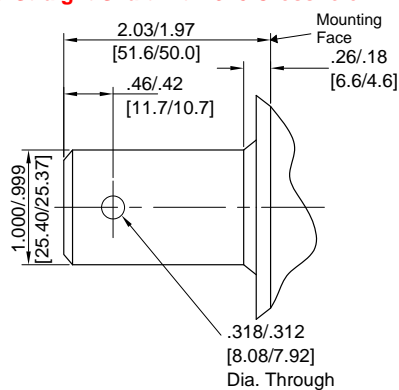

Code: H ** Special Order **
1 Inch Dia. Straight Shaft with .406 Crosshole

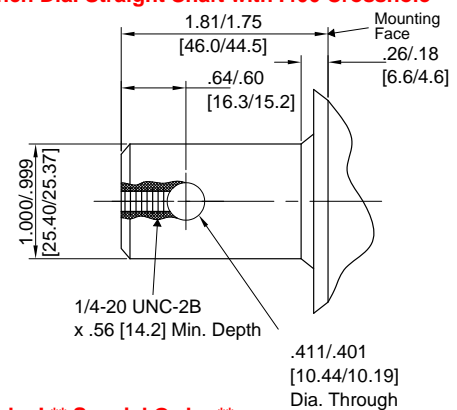

Code: S ** Special Order **
SAE 6 B 1" Dia. Splined Shaft

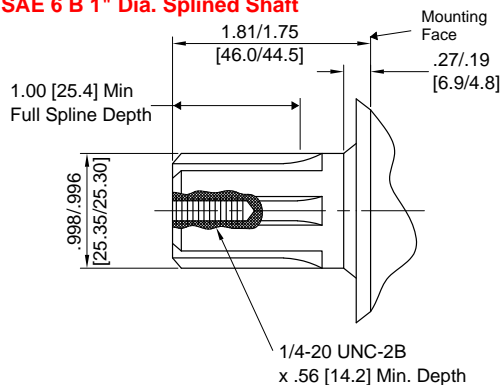

Code: I ** Special Order **
7/8" Dia. 13 tooth SAE-B Splined Shaft

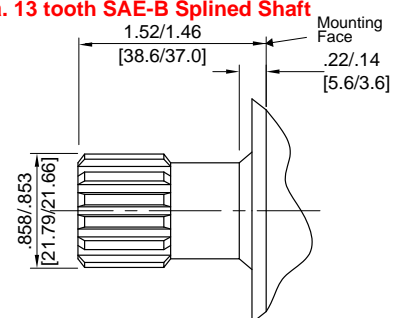

IFP BML MOTOR PERFORMANCE DATA



BML30: 3.1 in3/rev {51.3 cm3/rev}

BML49: 4.9 in3/rev {80.6 cm3/rev}

Flow GPM {LPM}	Pressure- PSI {Mpa}								max. Cont.	max. Int.
	725 {5}	1015 {7}	1305 {9}	1450 {10}	1740 {12}	2030 {14}	2320 {16}	2537 {17.5}		
1.3 {5}	310 {35}	398 {45}	539 {61}	592 {67}	681 {77}	778 {88}				
2.6 {10}	318 {36}	407 {46}	548 {62}	610 {69}	708 {80}	840 {95}	955 {108}	1062 {120}		
4.0 {15}	309 {35}	433 {49}	557 {63}	646 {73}	778 {88}	885 {100}	964 {109}	1088 {123}		
5.3 {20}	305 {34.5}	415 {47}	539 {61}	610 {69}	734 {83}	850 {96}	964 {109}	1115 {126}		
6.6 {25}	301 {34}	398 {45}	539 {61}	610 {69}	716 {81}	849 {96}	964 {109}	1115 {126}		
7.9 {30}	292 {33}	389 {44}	531 {60}	592 {67}	708 {80}	840 {95}	955 {108}	1115 {126}		
9.2 {35}	274 {31}	371 {42}	522 {59}	584 {66}	708 {80}	823 {93}	947 {107}	1097 {124}		
Max. Cont. 10.6 {40}	265 {30}	362 {41}	513 {58}	584 {66}	699 {79}	814 {92}	938 {106}	1079 {122}		
Max. Int. 11.9 {45}	261 {29.5}	354 {40}	504 {57}	575 {65}	690 {78}	796 {90}	929 {105}	1070 {121}		

Flow GPM {LPM}	Pressure- PSI {Mpa}								max. Cont.	max. Int.
	725 {5}	1015 {7}	1305 {9}	1450 {10}	1740 {12}	2030 {14}	2320 {16}	2537 {17.5}		
2.6 {10}	486 {55}	681 {77}	867 {98}	947 {107}	1150 {130}	1318 {149}	1504 {170}	1593 {180}		
5.3 {20}	442 {50}	722 {81.6}	929 {105}	1044 {118}	1168 {132}	1416 {160}	1575 {178}	1672 {189}		
5.3 {30}	424 {48}	654 {74}	858 {97}	1008 {114}	1159 {131}	1327 {150}	1584 {179}	1681 {190}		
10.6 {40}	398 {45}	628 {71}	840 {95}	929 {105}	1132 {128}	1318 {149}	1566 {177}	1663 {188}		
13.2 {50}	371 {42}	619 {70}	796 {90}	867 {98}	1106 {125}	1301 {147}	1513 {171}	1655 {187}		
15.9 {60}	336 {38}	557 {63}	752 {85}	840 {95}	1044 {118}	1256 {142}	1495 {169}	1637 {185}		
Max. Cont. 18.5 {70}	318 {36}	513 {58}	708 {80}	787 {89}	991 {112}	1230 {139}	1451 {164}	1584 {179}		
Max. Int. 19.8 {75}	256 {29}	495 {56}	681 {77}	752 {85}	973 {110}	1177 {133}	1421 {161}	1566 {177}		

Torque: lb-in {Nm}
Speed: RPM

BML61: 6.1 in3/rev {100.8 cm3/rev}

BML76: 7.6 in3/rev {124.9 cm3/rev}

Flow GPM {LPM}	Pressure- PSI {Mpa}								max. Cont.	max. Int.
	725 {5}	1015 {7}	1305 {9}	1450 {10}	1740 {12}	2030 {14}	2320 {16}	2537 {17.5}		
2.6 {10}	619 {70}	885 {100}	1079 {122}	1221 {138}	1407 {159}	1610 {182}	1858 {210}	1964 {222}		
5.3 {20}	601 {68}	840 {95}	1088 {123}	1265 {143}	1460 {165}	1770 {200}	1956 {221}	2106 {238}		
5.3 {30}	548 {62}	831 {94}	1070 {121}	1239 {140}	1451 {164}	1717 {194}	1947 {220}	2124 {240}		
10.6 {40}	522 {59}	778 {88}	1053 {119}	1185 {134}	1424 {161}	1699 {192}	1929 {218}	2106 {238}		
13.2 {50}	486 {55}	734 {83}	1035 {117}	1106 {125}	1389 {157}	1637 {185}	1920 {217}	2079 {235}		
15.9 {60}	424 {48}	699 {79}	973 {110}	1053 {119}	1345 {152}	1593 {180}	1894 {214}	2062 {233}		
Max. Cont. 18.5 {70}	380 {43}	619 {70}	885 {100}	991 {112}	1256 {142}	1504 {170}	1778 {201}	2026 {229}		
Max. Int. 19.8 {75}	345 {39}	557 {63}	858 {105}	929 {105}	1239 {140}	1478 {167}	1743 {197}	2009 {227}		

Flow GPM {LPM}	Pressure- PSI {Mpa}								max. Cont.	max. Int.
	725 {5}	1015 {7}	1305 {9}	1450 {10}	1740 {12}	2030 {14}	2320 {16}	2537 {17.5}		
2.6 {10}	796 {90}	1079 {122}	1416 {160}	1531 {173}	1814 {205}	2097 {237}	2283 {258}	2389 {270}		
5.3 {20}	752 {85}	1044 {118}	1407 {159}	1522 {172}	1840 {208}	2212 {250}	2460 {278}	2584 {292}		
5.3 {30}	725 {82}	947 {107}	1398 {158}	1451 {164}	1823 {206}	2133 {241}	2451 {277}	2575 {291}		
10.6 {40}	699 {79}	929 {105}	1327 {150}	1424 {161}	1805 {204}	2106 {238}	2433 {275}	2557 {289}		
13.2 {50}	663 {75}	849 {96}	1283 {145}	1416 {160}	1752 {198}	2088 {236}	2318 {262}	2495 {282}		
15.9 {60}	548 {62}	840 {95}	1230 {139}	1398 {158}	1619 {183}	1964 {222}	2248 {254}	2469 {279}		
Max. Cont. 18.5 {70}	522 {59}	734 {83}	1106 {125}	1327 {150}	1575 {178}	1876 {212}	2212 {250}	2318 {262}		
Max. Int. 19.8 {75}	495 {56}	708 {80}	1079 {122}	1283 {145}	1522 {172}	1814 {205}	2168 {245}	2310 {261}		

Torque: lb-in {Nm}
Speed: RPM

Continuous -
Intermittent -

IFF BML MOTOR PERFORMANCE DATA



BML98: 9.6 in³/rev {157.2 cm³/rev}

BML122: 12.2 in³/rev {199.2 cm³/rev}

		Pressure- PSI {Mpa}					max. Cont.	max. Int.	
		725 {5}	1015 {7}	1305 {9}	1450 {10}	1740 {12}	2030 {14}	2320 {16}	2537 {17.5}
Flow GPM {LPM}	2.6 {10}	1017 {115}	1416 {160}	1796 {203}	1947 {220}	2301 {260}	2655 {300}	3009 {340}	3203 {362}
	5.3 {20}	1008 {114}	1416 {160}	1814 {205}	2035 {230}	2345 {265}	2832 {320}	3142 {355}	3363 {380}
	5.3 {30}	929 {105}	1398 {158}	1787 {202}	1956 {221}	2310 {261}	2699 {305}	3044 {344}	3345 {378}
	10.6 {40}	885 {100}	1283 {145}	1734 {196}	1929 {218}	2274 {257}	2646 {299}	3009 {340}	3310 {374}
	13.2 {50}	796 {90}	1239 {140}	1681 {190}	1849 {209}	2212 {250}	2610 {295}	2973 {336}	3239 {366}
	15.9 {60}	743 {84}	1203 {136}	1593 {180}	1761 {199}	1977 {240}	2478 {286}	2832 {330}	3186 {360}
Max. Cont.	18.5 {70}	575 {65}	1062 {120}	1451 {164}	1593 {180}	1973 {223}	2478 {280}	2832 {320}	3097 {350}
Max. Int.	19.8 {75}	522 {59}	1026 {116}	1398 {158}	1548 {175}	1947 {220}	2407 {272}	2779 {314}	3026 {342}

		Pressure- PSI {Mpa}					max. Cont.	max. Int.
		725 {5}	1015 {7}	1305 {9}	1522 {10.5}	1740 {12}	2030 {14}	2537 {17.5}
Flow GPM {LPM}	2.6 {10}	1309 {148}	1814 {205}	2256 {255}	2566 {290}	2894 {327}	3274 {370}	3912 {442}
	5.3 {20}	1239 {140}	1787 {202}	2212 {250}	2858 {323}	2920 {330}	3637 {411}	3965 {448}
	5.3 {30}	1150 {130}	1708 {193}	2133 {241}	2717 {307}	2876 {325}	3336 {377}	3938 {445}
	10.6 {40}	1106 {125}	1646 {186}	2053 {232}	2699 {305}	2770 {313}	3451 {390}	3858 {436}
	13.2 {50}	1062 {120}	1566 {177}	1991 {225}	2610 {295}	2699 {305}	3380 {382}	3779 {427}
	15.9 {60}	973 {110}	1469 {166}	1956 {221}	2522 {285}	2584 {292}	3292 {372}	3708 {419}
Max. Cont.	18.5 {70}	867 {98}	1327 {150}	1814 {205}	2159 {244}	2460 {278}	2929 {331}	3628 {410}
Max. Int.	19.8 {75}	752 {85}	1247 {141}	1761 {199}	2079 {235}	2371 {268}	2858 {323}	3540 {400}

BML152: 15.4 in³/rev {252 cm³/rev}

Torque: lb-in {Nm}
Speed: RPM

		Pressure- PSI {Mpa}					max. Cont.	max. Int.	
		435 {3}	725 {5}	1015 {7}	1160 {8}	1450 {10}	1595 {11}	2030 {14}	2537 {17.5}
Flow GPM {LPM}	2.6 {10}	1017 {115}	1593 {180}	2221 {251}	2610 {295}	3097 {350}	3363 {380}	4159 {470}	4735 {535}
	5.3 {20}	973 {110}	1578 {178}	2230 {252}	2602 {294}	3115 {352}	3407 {385}	4159 {470}	4850 {548}
	5.3 {30}	885 {100}	1504 {170}	2194 {248}	2522 {285}	3080 {348}	3372 {381}	4150 {469}	4823 {545}
	10.6 {40}	805 {91}	1407 {159}	2053 {232}	2371 {268}	2938 {332}	3239 {366}	4071 {460}	4690 {530}
	13.2 {50}	716 {81}	1309 {148}	1911 {216}	2230 {252}	2832 {320}	3115 {352}	4009 {453}	4611 {521}
	15.9 {60}	663 {75}	1168 {132}	1778 {201}	2079 {235}	2699 {305}	3009 {340}	3832 {433}	4469 {505}
Max. Cont.	18.5 {70}	442 {50}	1035 {117}	1672 {189}	1947 {220}	2566 {290}	2832 {320}	3646 {412}	4381 {495}
Max. Int.	19.8 {75}	371 {42}	929 {105}	1593 {180}	1867 {211}	2487 {281}	2743 {310}	3584 {405}	4301 {486}

Continuous -
Intermittent -

IFP BML MOTOR PERFORMANCE DATA



BML192: 19.2 in³/rev {314.5 cm³/rev}

	Pressure- PSI {Mpa}							max.	max.	
	435	725	943	1160	1305	1885	1957	Cont.	Int.	
Flow GPM {LPM}	2.6 {10}	1194 {135}	1902 {215}	2469 {279}	3035 {343}	3389 {383}	4558 {515}	4867 {550}		
	5.3 {20}	1177 {133}	1911 {216}	2557 {289}	3088 {349}	3363 {380}	4496 {508}	4885 {552}		
	5.3 {30}	1106 {125}	1814 {205}	2433 {275}	3018 {341}	3319 {375}	4372 {494}	4805 {543}		
	10.6 {40}	1000 {113}	1725 {195}	2363 {267}	2964 {335}	3248 {367}	4292 {485}	4655 {526}		
	13.2 {50}	814 {92}	1504 {170}	2239 {253}	2841 {321}	3115 {352}	4195 {474}	4522 {511}		
	15.9 {60}	708 {80}	1416 {160}	2044 {231}	2699 {305}	2956 {334}	4053 {458}	4354 {492}		
	Max. Cont. {70}	504 {57}	1203 {136}	1902 {215}	2522 {285}	2832 {320}	3929 {444}	4248 {480}		
	Max. Int. {75}	486 {55}	1097 {124}	1814 {205}	2380 {269}	2726 {308}	3779 {427}	4150 {469}		

BML244: 22.6 in³/rev {370 cm³/rev}

	Pressure- PSI {Mpa}							max.	max.	
	435	725	943	1160	1305	1885	1957	Cont.	Int.	
Flow GPM {LPM}	2.6 {10}	1416 {160}	2389 {270}	3009 {340}	3717 {420}	4159 {470}	4867 {550}	5398 {610}		
	5.3 {20}	1407 {159}	2301 {260}	3009 {340}	3628 {410}	4159 {470}	4779 {540}	5354 {605}		
	5.3 {30}	1327 {150}	2256 {255}	2920 {330}	3540 {400}	3982 {450}	4690 {530}	5310 {600}		
	10.6 {40}	1194 {135}	2124 {240}	2743 {310}	3319 {375}	3805 {430}	4602 {520}	5221 {590}		
	13.2 {50}	1062 {120}	2035 {230}	2610 {295}	3186 {360}	3717 {420}	4469 {505}	5044 {570}		
	15.9 {60}	867 {98}	1858 {210}	2433 {275}	3009 {340}	3451 {390}	4336 {490}	4867 {550}		
	Max. Cont. {70}	663 {75}	1548 {175}	2212 {250}	2832 {320}	3274 {370}	4115 {465}	4690 {530}		
	Max. Int. {75}	575 {65}	1416 {160}	2035 {230}	2743 {310}	3186 {360}	3982 {450}	4558 {515}		

Torque: lb-in
{Nm}
Speed: RPM

Continuous -
Intermittent -

IFP HIGH TORQUE GEROTER / ROLLER MOTORS

Parts Service Information



"BML SERIES"

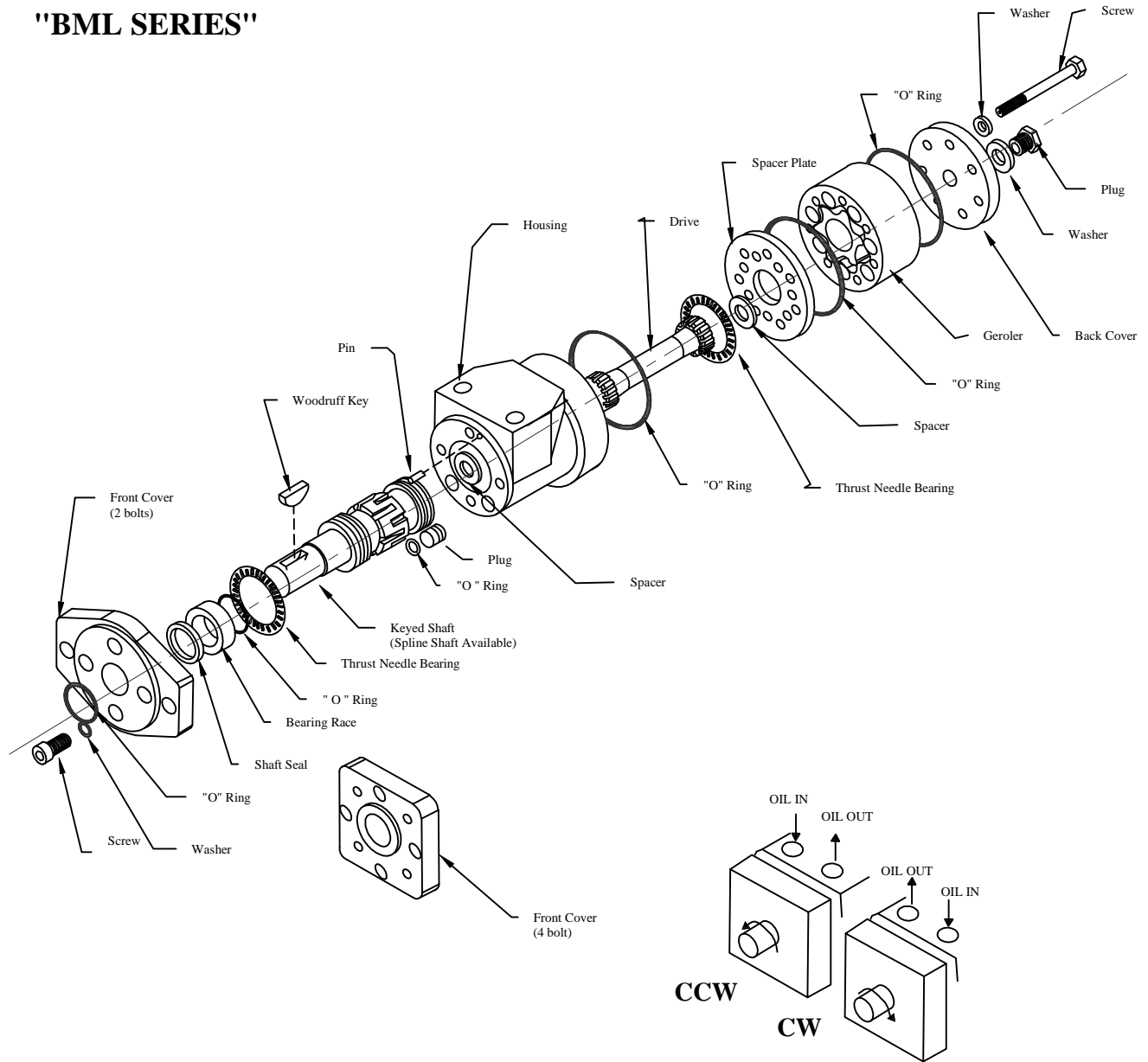

MOTOR ROTATION

FACTORY TIMING OF MOTOR WILL PRODUCE FOLLOWING ROTATIONS WHEN INLET AND OUTLET PORTS ARE ORIENTATED AS SHOW AS ABOVE DIAGRAMS

CROSS REFERENCE BML GEROLER SERIES



*INDICATES STANDARD STOCK UNITS
STANDARD 4 BOLT/KEYED SHAFT(SPLINE SHAFTS AVAILABLE)

IFP MODEL	DISPL in/rev	CHARLYNN "S" MODEL	DISPL in/rev	DANFOSS "OMR" MODEL	DISPL in/rev	PORTS SIZE
BML030-4PK *BML030-4SK	3.0	103-1573 103-1570	3.6	151-2421 151-2341	3.1	1/2 NPTF SAE 7/8-14
BML049-4PK *BML049-4SK	4.9	103-1002 103-1010	4.5	151-2422 151-2342	4.9	1/2 NPTF SAE 7/8-14
BML061-4PK *BML061-4SK	6.1	103-1003 103-1011	5.9	151-2423 151-2343	6.1	1/2 NPTF SAE 7/8-14
BML076-4PK *BML076-4SK	7.6	103-1574 103-1571	7.3	151-2424 151-2344	7.7	1/2 NPTF SAE 7/8-14
		103-1575 103-1572	8.9	151-2224 151-2421		1/2 NPTF SAE 7/8-14
BML098-4PK *BML098-4SK	9.8	103-1004 103-1012	9.7	151-2425 151-2345	9.7	1/2 NPTF SAE 7/8-14
BML122-4PK *BML122-4SK	12.2	103-1005 103-1013	11.3	151-2426 151-2346	12.2	1/2 NPTF SAE 7/8-14
BML152-4PK *BML152-4SK	15.2	103-1006 103-1014	14.1	151-2427 151-2347	15.2	1/2 NPTF SAE 7/8-14
BML192-4PK *BML192-4SK	19.2	103-1007 103-1015	17.9	151-2428 151-2348	19.3	1/2 NPTF SAE 7/8-14
BML244-4PK *BML244-4SK	22.6	103-1008 103-1016	22.6	151-2429 151-2349	22.7	1/2 NPTF SAE 7/8-14

STANDARD 2 BOLT/KEYED SHAFT(SPLINE SHAFTS AVAILABLE)

IFP MODEL	DISPL in/rev	CHARLYNN "H" MODEL	DISPL in/rev	DANFOSS "OMR" MODEL	DISPL in/rev	PORTS SIZE
BML030-2PK *BML030-2SK	3.0	103-1540 103-1537	3.6	151-2084 151-2001	3.1	1/2 NPTF SAE 7/8-14
BML049-2PK *BML049-2SK	4.9	103-1026 103-1034	4.5	151-2082 151-2002	4.9	1/2 NPTF SAE 7/8-14
BML061-2PK *BML061-2SK	6.1	103-1027 103-1035	5.9	151-2083 151-2003	6.1	1/2 NPTF SAE 7/8-14
BML076-2PK *BML076-2SK	7.6	103-1541 103-1538	7.3	151-2084 151-2004	7.7	1/2 NPTF SAE 7/8-14
		103-1542 103-1539	8.9			1/2 NPTF SAE 7/8-14
BML098-2PK *BML098-2SK	9.8	103-1028 103-1036	9.7	151-2085 151-2005	9.7	1/2 NPTF SAE 7/8-14
BML122-2PK *BML122-2SK	12.2	103-1029 103-1037	11.3	151-2086 151-2006	12.2	1/2 NPTF SAE 7/8-14
BML152-2PK *BML152-2SK	15.2	103-1030 103-1038	14.1	151-2087 151-2007	15.2	1/2 NPTF SAE 7/8-14
BML192-2PK *BML192-2SK	19.2	103-1031 103-1039	17.9	151-2088 151-2008	19.3	1/2 NPTF SAE 7/8-14
BML244-2PK *BML244-2SK	22.6	103-1032 103-1040	22.6	151-2089 151-2009	22.7	1/2 NPTF SAE 7/8-14

IFP BML HIGH TORQUE LOW SPEED MOTORS



TIMING PROCEDURE

STANDARD ROTATION

Motor rotation will be as shown in Figure #1 when the following timing procedure is used

- Position tooth slot#1 on shaft assembly in line with tooth slot#3 highest point of geroter

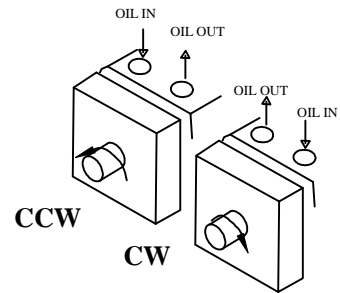
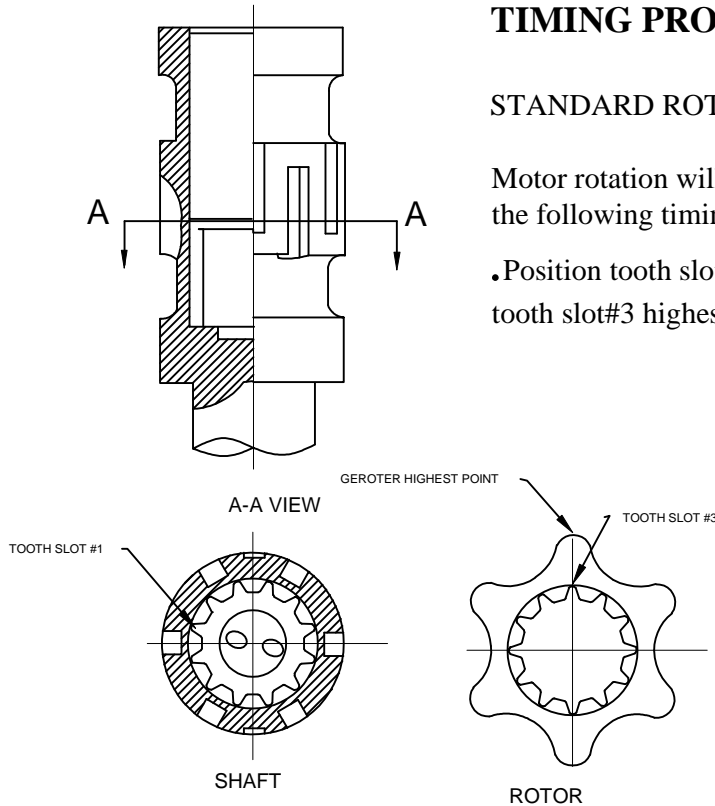

Figure #1
When timing is orientated as shown

TIMING PROCEDURE

REVERSE ROTATION

Motor rotation will be as shown in Figure #2 when the following timing procedure is used

- Position tooth slot#2 on shaft assembly in line with tooth slot#3 highest point of geroter

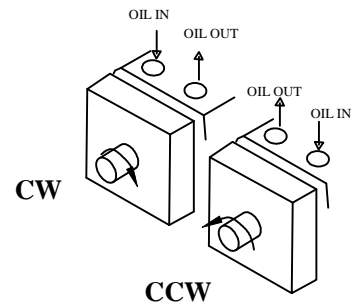
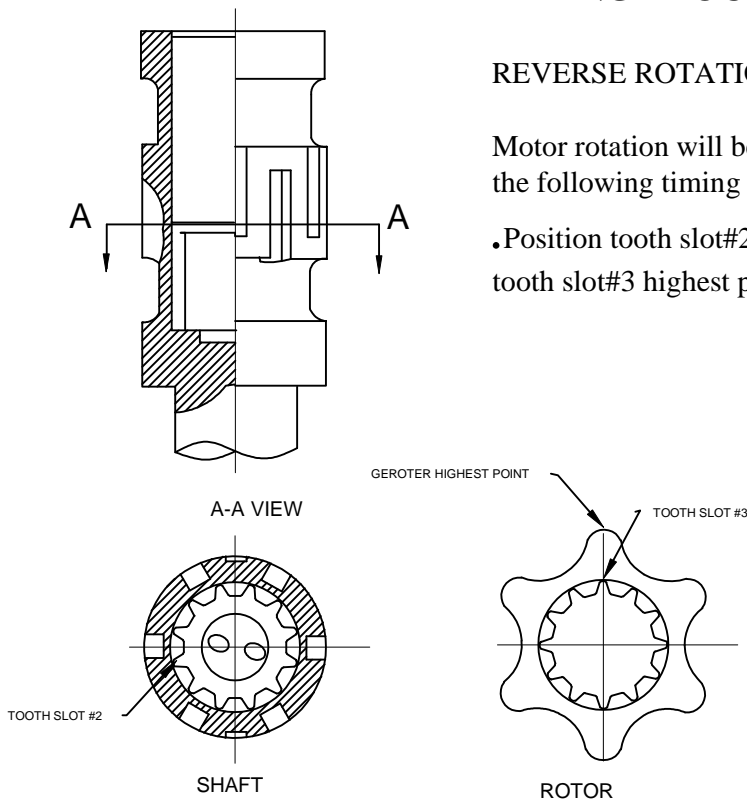

Figure #2
When timing is orientated as shown